

Micro 3D HA

Coordinate Measuring Machines

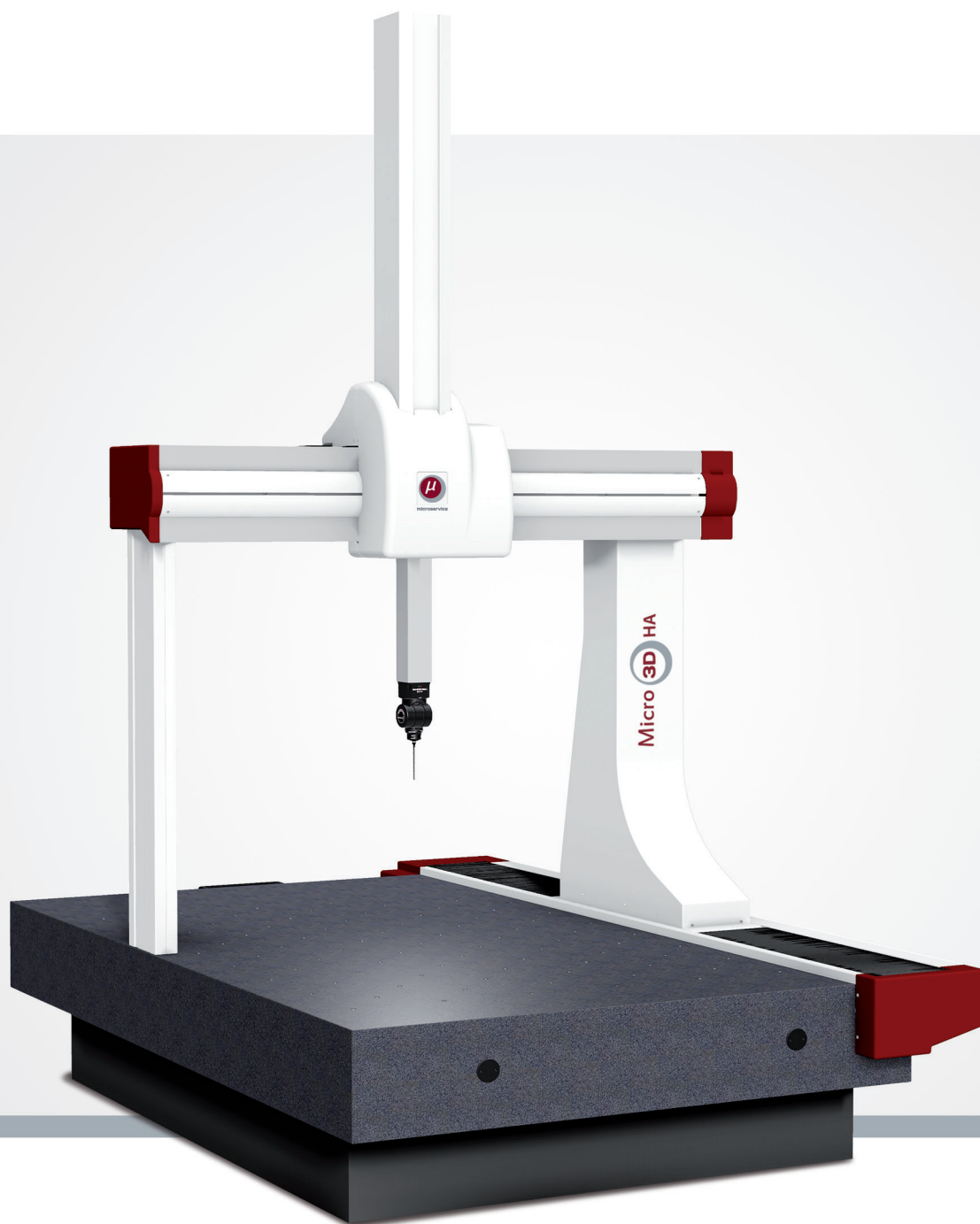

MICRO 3D HA
SPECIFICATIONS
Release 2022-04





DYNAMICS

			xx.07.07	xx.09.08	xx.10.08	xx.10.09	xx.10.10	xx.12.10	xx.15.10	xx.15.13
Cruise Speed max.	Motorized (axes)	mm/s	0 - 100	0 - 100	0 - 100	0 - 100	0 - 100	0 - 100	0 - 100	0 - 100
	CNC (vector)	mm/s	866	866	866	866	866	866	866	800
Acceleration	CNC (vector)	mm/s ²	2000	2000	2000	1500	1200	1200	1000	900

SCANNING PROBE HEADS

Volumetric Length meas. Error, MPE as per ISO 10360-2:2009 ¹⁾	E0/E150	μm	T1	1,5 + L/333	1,5 + L/333	1,7 + L/333	1,9 + L/333	2,4 + L/333	2,4 + L/333	2,5 + L/285	3,0 + L/285
	E0/E150	μm	T2	2,2 + L/200	2,3 + L/200	2,8 + L/200	2,8 + L/200	3,3 + L/200	3,3 + L/200	3,3 + L/166	3,7 + L/166
Repeatability range, MPL as per ISO 10360-2:2009	RO	μm		1,4	1,4	1,6	1,8	2,3	2,3	2,4	2,9
Single stylus form error, MPE as per ISO 10360-5:2010	PFTU	μm		1,5	1,5	1,7	1,9	2,4	2,4	2,5	3,0
Single Stylus form error, scanning. MPE as per ISO 10360-4:2000 ³⁾	THP	μm		3,0	3,0	3,4	4,0	4,8	4,8	5,0	6,0
Required measuring time MPT	T	s		60	60	60	60	60	60	60	60
Single Stylus form error, scanning. MPE as per ISO 10360-4:2000 ³⁾	THN	μm		3,0	3,0	3,4	4,1	4,8	4,8	5,0	6,0
Required measuring time MPT	T	s		70	70	70	70	70	70	70	70
Form measurement error	RONt (MZCI) ²⁾	μm		1,6	1,6	1,8	2,0	2,5	2,5	2,6	3,1

INDEXING HEADS OR FIXED HEADS WITH STRAIN-GAUGE TRIGGER PROBE

Volumetric Length meas. Error, MPE as per ISO 10360-2:2009 ¹⁾	E0/E150	μm	T1	1,8 + L/333	1,8 + L/333	1,9 + L/333	2,0 + L/333	2,4 + L/333	2,5 + L/333	2,6 + L/285	3,0 + L/285
	E0/E150	μm	T2	2,2 + L/200	2,2 + L/200	2,3 + L/200	2,8 + L/200	2,8 + L/200	3,3 + L/200	3,3 + L/166	3,7 + L/166
Repeatability range, MPL as per ISO 10360-2:2009	RO	μm		1,7	1,7	1,8	1,9	2,3	2,4	2,5	2,9
Single stylus form error, MPE as per ISO 10360-5:2010	PFTU	μm		1,8	1,8	1,9	2,0	2,4	2,5	2,6	3,0

INDEXING HEADS OR FIXED HEADS WITH TRIGGER PROBE

Volumetric Length meas. Error, MPE as per ISO 10360-2:2009 ¹⁾	E0/E150	μm	T1	1,9 + L/333	1,9 + L/333	2,0 + L/333	2,2 + L/333	2,5 + L/333	2,7 + L/333	2,8 + L/333	3,5 + L/333
	E0/E150	μm	T2	2,4 + L/200	2,4 + L/200	2,5 + L/200	3,0 + L/200	3,0 + L/200	3,5 + L/200	3,5 + L/200	4,0 + L/200
Repeatability range, MPL as per ISO 10360-2:2009	RO	μm		1,8	1,8	1,9	2,1	2,4	2,6	2,7	3,4
Single stylus form error, MPE as per ISO 10360-5:2010	PFTU	μm		2,0	2,0	2,1	2,2	2,5	2,7	2,8	3,5

METROLOGICAL SPECIFICATIONS

	TEMPERATURES		TOOLS / STYLUS CONFIGURATIONS	
	Ambient T1	Ambient T2	REVO	
Measuring Reference Temperature	18 °C to 22 °C	16 °C to 26 °C	SP25	RSP2/RSH175 - RSP3-1/SH25-1, stylus L = 20 mm Stylus Ø5 x 50 mm
Maximum air temperature variations	1,0 °C/h - 2,0 °C/24h	1,0 °C/h - 5,0 °C/24h	TP200	Standard Force Module and stylus Ø4 x 10 mm
Maximum spatial gradient	1,0 °C / m	1,0 °C / m	Trigger Probe	Standard Force Module and stylus Ø4 x 10 mm

1) Measuring length L in mm.

2) RONt test available on SP80 probe head, with Stylus Ø5 x 50 mm, 50 mm ring gauge, speed 5 mm/s, located in the middle of the measuring Volume.

3) For MPE(THP/THN) and MPT(T): sphere is placed in the middle of the measuring volume.

GENERAL DIMENSIONS



From 10.07.07 to 20.10.08

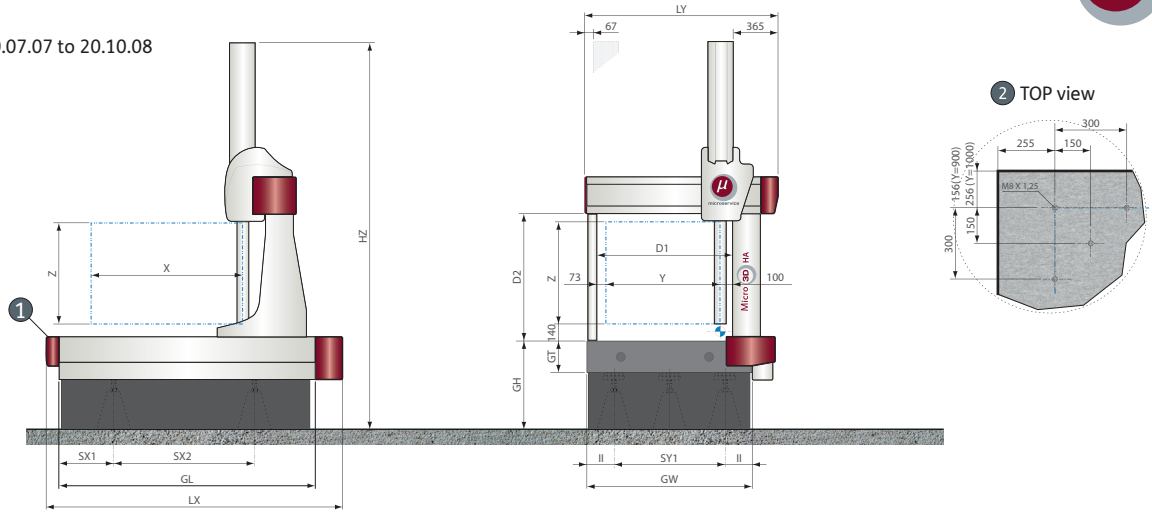

Sizes	Measuring range			Overall dimensions			Surface plate				Support position			Daylights		Weights	
	X	Y	Z ⁽¹⁾	Length	Width	Height	mm				SX1	SX2	SY1	D1	D2	daN	
							Height	Thick.	Length	Width						Max. workpiece	Machine
MX	MY	MZ	LX	LY	HZ	GH	GT	GL	GW								
10.07.07	1000	700	700	2152	1317	2843	670	200	1830	1110	415	1000	700	873	909	900	1380
12.09.08	1200	900	800	2352	1524	3073	700	250	2030	1310	455	1120	880	1073	1009	1300	2125
15.09.08	1500	900	800	2652	1524	3073	700	250	2330	1310	540	1250	880	1073	1009	1500	2400
20.09.08	2000	900	800	3152	1524	3073	700	250	2830	1310	665	1500	880	1073	1009	1800	2860
30.09.08	3000	900	800	4152	1524	3073	700	400	3830	1310	665	2100	880	1073	1009	4000	5910
12.10.08	1200	1000	800	2352	1624	3073	700	250	2030	1410	455	1120	980	1173	1009	1400	2270
15.10.08	1500	1000	800	2652	1624	3073	700	250	2330	1410	540	1250	980	1173	1009	1600	2570
20.10.08	2000	1000	800	3152	1624	3073	700	250	2830	1410	665	1500	980	1173	1009	1900	3070
25.10.08	2500	1000	800	3652	1624	3073	700	360	3330	1410	665	2800	980	1173	1009	2200	4600
15.10.09	1500	1000	900	2832	1737	3339	700	250	2510	1440	555	1400	960	1180,5	1111	1500	2890
20.10.09	2000	1000	900	3332	1737	3339	700	290	3010	1440	655	1700	960	1180,5	1111	1600	3890
15.10.10	1500	1000	1000	2832	1737	3539	700	250	2510	1440	555	1400	960	1180,5	1211	1500	2890
20.10.10	2000	1000	1000	3332	1737	3539	700	290	3010	1440	655	1700	960	1180,5	1211	1600	3900
15.12.10	1500	1200	1000	2832	1937	3539	700	290	2510	1640	555	1400	1100	1380,5	1211	1800	3730
20.12.10	2000	1200	1000	3332	1937	3539	700	340	3010	1640	655	1700	1100	1380,5	1211	2300	5100
25.12.10	2500	1200	1000	3832	1937	3539	700	360	3510	1640	780	1950	1100	1380,5	1211	2400	6210
30.12.10	3000	1200	1000	4332	1937	3539	700	400	3510	1640	780	2200	1100	1380,5	1211	4000	7780
20.15.10	2000	1500	1000	3332	2237	3539	700	360	3010	1940	655	1700	1300	1680,5	1211	3600	6330
25.15.10	2500	1500	1000	3822	2237	3539	700	400	3510	1940	780	1950	1300	1680,5	1211	4000	8080
30.15.10	3000	1500	1000	4332	2237	3539	700	420	4010	1940	895	2220	1300	1680,5	1211	4000	9695
20.15.13	2000	1500	1300	3332	2237	4139	700	360	3010	1940	655	1700	1300	1680,5	1511	3600	6650
25.15.13	2500	1500	1300	3832	2237	4139	700	400	3510	1940	780	1950	1300	1680,5	1511	4000	8300
30.15.13	3000	1500	1300	4332	2237	4139	700	420	4010	1940	895	2220	1300	1680,5	1511	4000	9850

From 15.10.09 to 30.15.13

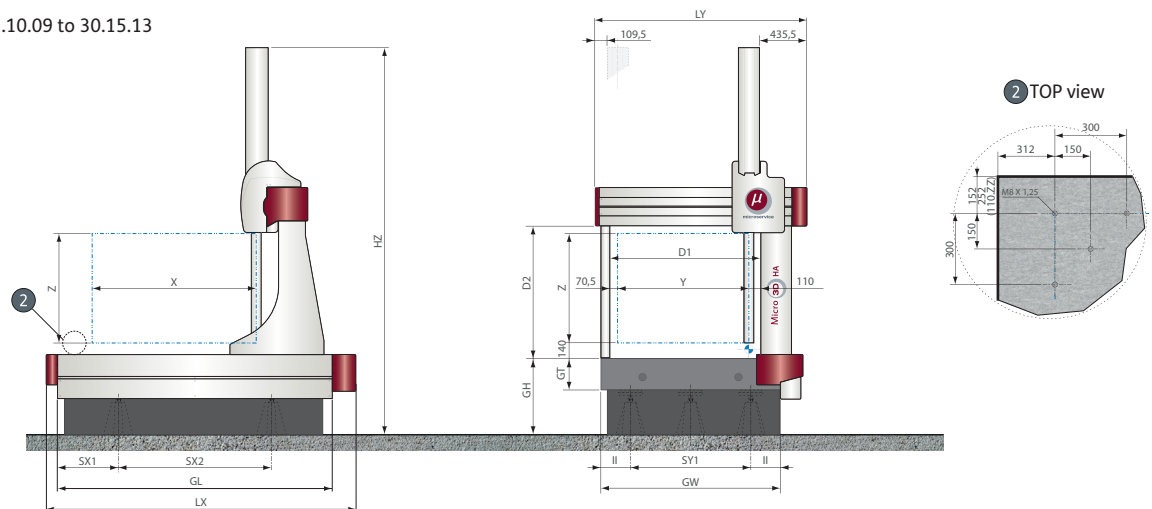

1) With REVO, Z measuring stroke is reduced by 48 mm



PROBE HEADS

EAGLE.head m 7.5 PKJ™

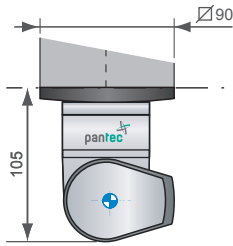

PH10MQ

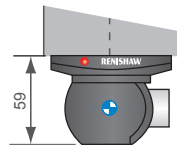

SP80



REVO

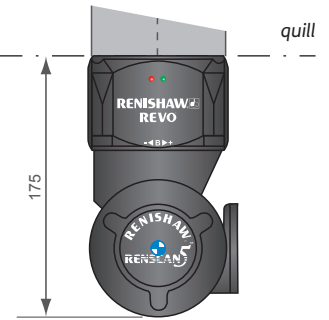

TECHNICAL FEATURES

Mechanical frame	Coordinate Measuring Machine, CNC type, with mobile bridge structure on granite table machine base
Sliding guideways	X axis: dovetail, machined into the granite table. Y/Z axes: micromachined, anodized light alloy extrusion
Sliding elements	Air bearings
Drive system	Direct drive belt all axes
Length measuring system	Free-moving linear transducers on carrier, resolution 0,1 μm
Controller	Pantec EAGLE™ / Renishaw® UCC
	Protection degree: IP40 (IP54 upon request)
	Cooling system: Fan
Surface Plate (part locking)	Granite, threaded inserts M8x1,25: flatness according to DIN 876/3
Vibration damping system ¹⁾	Passive elastometer vibration damping
Options	Automatic tip/tool changer, Automatic multisensor temperature compensation for T2 (16 °C to 26 °C), on top rotary table, manual and automated part loading system, active pneumatic vibration damping. ¹⁾ if requested, we will perform a vibration analysis.

ELECTRIC AND COMPRESSED AIR SUPPLY

Power Supply	1/N/PE 115/230 V~ ± 10 %; 50 / 60 Hz (± 4 %)	Compressed air supply	From 0,6 to 1,0 MPa, pre-cleaned
Max. power consumption	2,5 kVA	Operating Pressure	≤ 0,5 MPa
Typ. power consumption	0,6 kVA	Consumption	≤ 250 Nl/min
		Quality	According ISO 8573 part 1: class 4

ENVIRONMENT

Humidity	40 % to 80 % UR (non condensing)
Operating Temperature	From 15 °C to 35 °C
Acceptable Vibrations	(Peak to Peak acceleration) 30 mm/s ² from 1 to 10 Hz 15 mm/s ² from 10 to 20 Hz 50 mm/s ² from 20 to 100 Hz

SAFETY

Regulations

Micro 3D HA complies with EC machine directive 2006/42/EC and EMC directive 2004/108/EEC

Disposal

Microservice products and packaging returned to us are disposed of in accordance with applicable legal provisions.

Microservice Srl

Via dei Ronchi, 45/L
10091 Alpignano (TO) / Italy
+39 011 9682524
sales@micro3d.it
micro3d.it

EN_Micro3DHA_22_Q2. Printed in Italy. MS-IV/2022
Specifications subject to change, due to the continuous improvement of the product.

Printed on recycled paper. Concept: Masterprint
Text and design: Microservice.